

# *BioPette™*

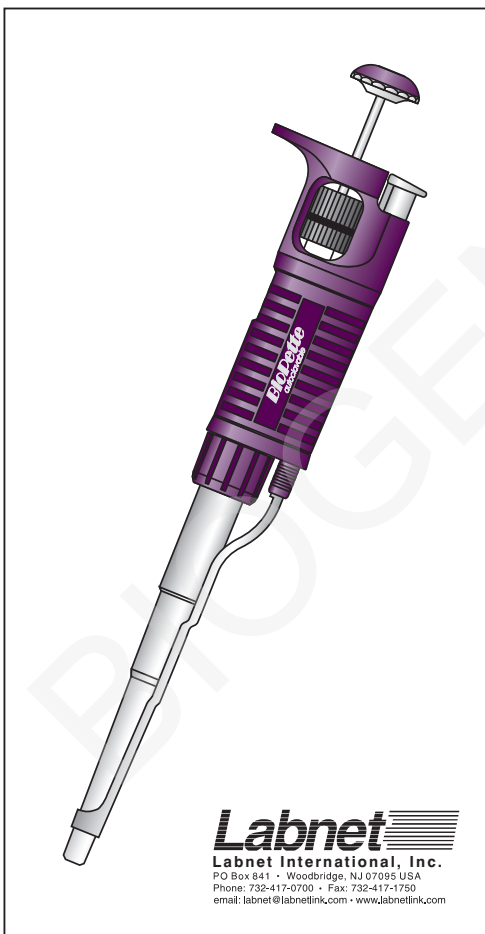

# BioPette™

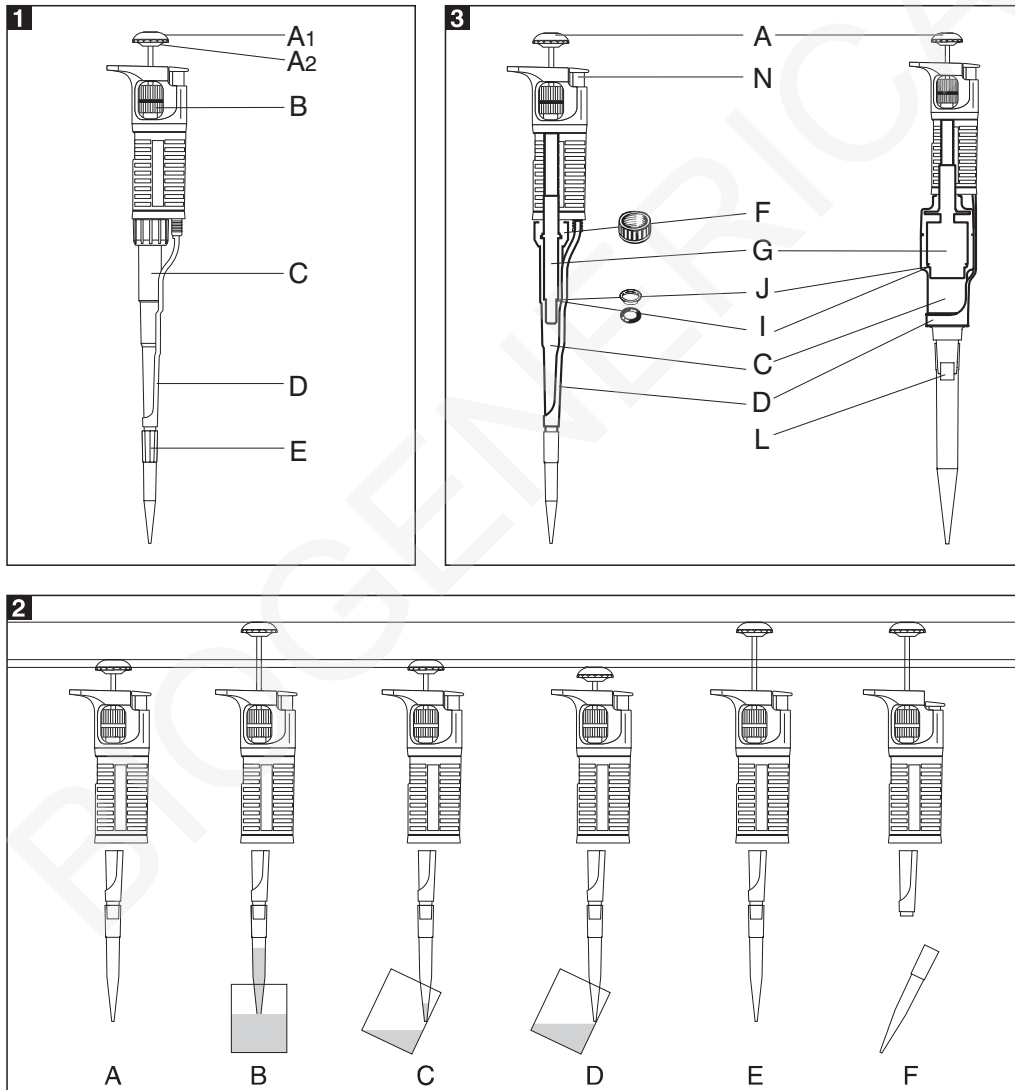

# BioPetite™

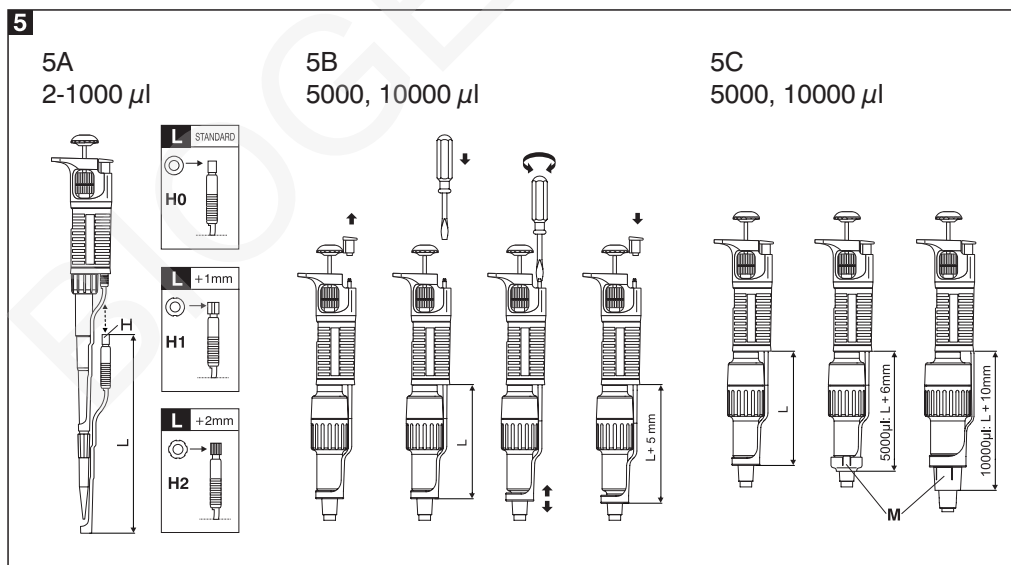
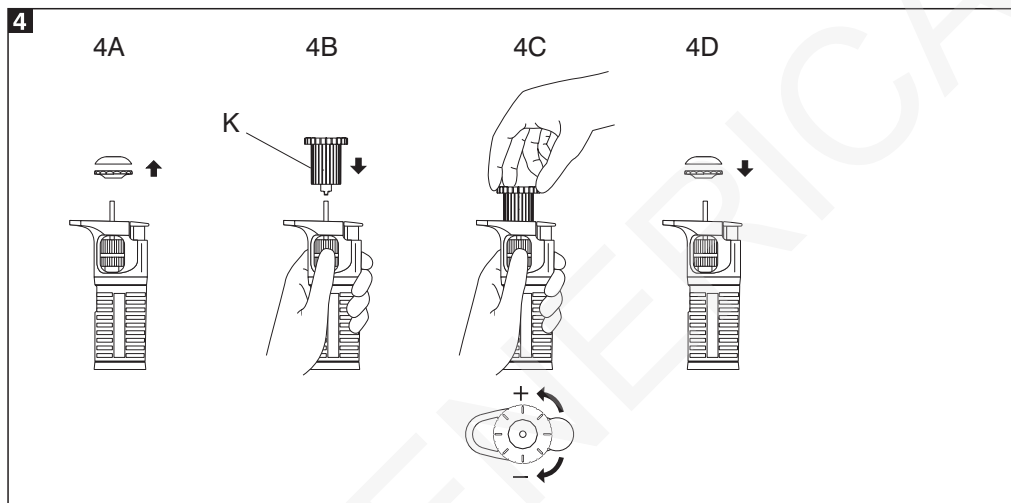

# BioPette™

## CONTENTS

- 1 - INTRODUCTION
- 2 - SETTING THE VOLUME
- 3 - OPERATION
- 4 - PRE-RINSING
- 5 - DENSE AND VISCOUS LIQUIDS
- 6 - LABNET PIPETTE TIPS
- 7 - RECOMMENDATIONS
- 8 - RECALIBRATION
- 9 - TROUBLESHOOTING
- 10 - CLEANING AND STERILIZATION
- 11 - PIPETTE KIT AND ACCESSORIES
- 12 - SPARE PARTS

## 1 - INTRODUCTION

The **BioPette™** is a volumetric instrument designed to measure and transfer liquids precisely and safely. It can measure and transfer volumes from 0.1  $\mu\text{l}$  to 10000  $\mu\text{l}$  depending on the model.

The **BioPette™** has a digital counter displaying the set volume. The set volume is visible in the window on the handle. The setting of the volume is done by turning of the pipetting pushbutton knob (Fig. 1A2) or by turning of the black knurled adjustment knob (Fig. 1B) in the right direction. The volume range is shown on the pipetting pushbutton (Fig. 1A1). The volume range from 0.1  $\mu\text{l}$  to 10000  $\mu\text{l}$  is covered by eight pipette models.

Model	Volume range [ $\mu\text{l}$ ]
BP2	0.1 - 2
BP10	0.5 - 10
BP20	2 - 20
BP100	10 - 100
BP200	20 - 200
BP1000	100 - 1000
BP5000	1000 - 5000
BP10000	1000 - 10000

BP2, BP10	Measurement and transfer of micro-volumes, DNA sequencing and enzyme-assay applications.
BP20, BP100, BP200 and BP1000	Measurement and transfer of general aqueous solution, acids and bases
BP5000, BP10000	Measurement and transfer of large volumes

The **BioPette™** uses disposable polypropylene tips, Fig. 1E. The disposable tips ensure maximum safety for the user and no cross contamination between samples. To protect the user from contamination by the tips, the **BioPette™** is equipped with a built-in tip ejector, Fig. 1D.

When using very narrow test tubes, it may be necessary to remove the tip ejector. It is simply removed by pulling down.

### Adjusting Tip Ejector length

- models BP2 to BP1000 pipettes (Fig. 5A)

The interchangeable "H" spacers, included in the box, allow for adjusting the length of the tip ejector by +1 mm or +2 mm. An "H0" spacer is inserted on a standard basis. The outside shape of the spacer identifies the size change.

- in BP5000 and BP10000  $\mu\text{l}$  pipettes (Fig. 5B).

The length of tip ejector is regulated by screwing in or screwing out the tip ejector stem with a screwdriver. Turn the screwdriver counter clockwise to increase the length of tip ejector, and clockwise to reduce the length of tip ejector. The ejector can be adjusted in the range of 5 mm. If above described method of ejector adjustment is not sufficient or the diameter of the ejector opening is too large to eject the tip it is necessary to put the ejector cap "M" onto the ejector, (Fig. 5C).

# BioPette™

Adjusting the length of the ejector will enable you to use your **BioPette™** with virtually any tip found on the market.

The **BioPette™** is a high quality instrument which offers excellent accuracy and precision. The figures for accuracy and precision given in the following table were obtained using **Labnet** tips. These figures are only guaranteed when **Labnet** tips are used.

SPECIFICATIONS			
Model	Volume [μl]	Accuracy [%]	Precision [%]
BP2	0.2	± 12.0	± 6.0
	1.0	± 2.7	± 1.3
	Max. 2.0	± 1.5	± 0.7
BP10	Min. 0.5	± 4.0	± 2.8
	5.0	± 1.0	± 0.6
	Max. 10.0	± 0.5	± 0.4
BP20	Min. 2	± 3.0	± 1.5
	10	± 1.0	± 0.5
	Max. 20	± 0.8	± 0.3
BP100	Min. 10	± 1.6	± 0.80
	50	± 0.8	± 0.24
	Max. 100	± 0.8	± 0.20
BP200	Min. 20	± 1.2	± 0.60
	100	± 0.8	± 0.25
	Max. 200	± 0.6	± 0.20
BP1000	Min. 100	± 0.9	± 0.40
	500	± 0.7	± 0.20
	Max. 1000	± 0.6	± 0.15
BP5000	Min. 1000	± 0.6	± 0.25
	2500	± 0.6	± 0.20
	Max. 5000	± 0.5	± 0.15
BP10000	Min. 1000	± 2.5	± 0.6
	5000	± 0.8	± 0.3
	Max. 10000	± 0.5	± 0.2

These specifications are obtained in forward mode, using a gravimetric method with the temperature of the distilled water, tips and all other conditions stabilized between 19°C and 21°C. Number of measurements - minimum 10. The values given include all components of error due to both normal handwarming and the changing of the tip.

Performance test: The pipette is calibrated in accordance with EN ISO 8655. Performance can be verified by checking the pipette using the procedures outlined in the EN ISO 8655 standard.

The pipette design enables the user to perform the recalibration process according to the rules presented in section 8.

## 2 - SETTING THE VOLUME

The volume display consists of three numbers and is read from top to bottom. The three numbers indicate the volume selected and are colored black and red.

For the BP2, BP10, BP20, BP100 and BP200 pipettes, the numbers in black represent microliters and the numbers in red represent tenths and hundredths of microliters.

*AN EXAMPLE FOR EACH OF THESE PIPETTES IS GIVEN BELOW*

BP2	BP10	BP20	BP100	BP200
1	0	1	0	1
2 red	7	2	7	2
5 red	5 red	5 red	5	5
1.25 μl	7.5 μl	12.50 μl	75 μl	125 μl

For the BP1000, BP5000 and BP10000 pipettes, the numbers in red represent milliliters and the numbers in black represent microliters.

*AN EXAMPLE FOR EACH OF THESE PIPETTES IS GIVEN BELOW*

BP1000	BP5000	BP10000
0 red	1 red	0 red
7	2	7 red
5	5	5
0.75 ml	1.25 ml	7.5 ml

The volume of the pipette is set by the knob in the pipetting pushbutton (Fig. 1A2) or by the black adjustment knob (Fig. 1B).

To attain the maximum accuracy, set volume must be approached from a higher value. If the desired value is lower than the previous value, simply use the knob in the pushbutton (Fig. 1A2) or the black adjustment knob (Fig. 1B) to adjust

# BioPette™

the value down to 1/3 turn above the required setting. If the desired value is higher than the previous value, use the knob in the pushbutton or the black adjustment ring to adjust the value to 1/3 turn above the required value. The setting should then be performed in the following manner:

With the volume set to 1/3 above the required setting, slowly turn the pipetting pushbutton knob or the black adjustment knob to the required volume.

If the knob is accidentally turned too far, ie is set lower than the required value, the process must be repeated. The approach to the set volume must always be made in the order of decreasing value.

## 3 - OPERATION

Place a tip on the shaft of the pipette. See Section 6 for the appropriate tip. Press the tip on firmly using a slight twisting motion to ensure a positive, airtight seal.

Note: Never handle a liquid with a **BioPette™** which has not been fitted with a tip.

### Aspiration

Press the pushbutton to the first positive stop, Fig. 2A. Holding the pipette vertically, immerse the tip into the sample liquid. The depth to which the tip is immersed in the sample liquid depends on the model.

BP2 and BP10	≤1 mm
BP20 and BP100	2 - 3 mm
BP200 and BP1000	2 - 4 mm
BP5000, BP10000	3 - 6 mm

Release the pushbutton slowly and smoothly to aspirate the sample, Fig. 2B. Wait one second and then withdraw the tip from the liquid. Wipe any droplets away from the outside of the tip using a medical wipe.

### Avoid touching the orifice of the tip.

### Dispensing

- Place the end of the tip against the inside wall of the vessel at an angle of 10 to 40 degrees.

- Press the pushbutton smoothly to the first stop, Fig. 2C. Wait one second.
- Press the pushbutton to the second stop to expel any remaining liquid, Fig. 2D.
- Keeping the pushbutton pressed to the end, remove the pipette by drawing the tip along the inside surface of the vessel.
- Release the pushbutton, Fig. 2E.
- Eject the tip by pressing the tip ejector button, Fig. 2F. It is only necessary to change the tip if a different liquid is being sampled or if the volume setting is changed.

### Filters

A replaceable filter installed in a seat in the bottom part of the shaft is used in 5000  $\mu$ l and 10000  $\mu$ l pipettes (Fig. 3L). The filter prevents the aspirated liquid from entering into the shaft and thus from polluting the inside of the shaft and the piston. Using the filter is especially important when aspirating and dispensing large volumes of liquid.

If the filter becomes wet during liquid aspiration it should be replaced with a new one.

## 4 - PRE-RINSING

When pipetting liquids which have a viscosity and density different than water, for example organic solvents, a film of liquid is formed on the inside wall of the pipette tip. This film can create an error. Since the film remains relatively constant in successive pipetting operations with the same tip, this error can be avoided by forming the film before transferring the first sample. This is done by aspirating a sample and dispensing it back into the same vessel. Since the film is already formed, all of the following samples will have better accuracy and repeatability.

This pre-rinsing operation should be repeated when the volume to be aspirated is changed or when a new tip is used.

# BioPette™

## 5 - DENSE AND VISCOUS LIQUIDS

For moderately dense or viscous liquids, compensation is possible by setting the volumeter higher than the required value.

For liquids which are less dense than water, compensation is possible by setting the volumeter lower than the required value.

*Example: to transfer 10  $\mu$ l of serum using BioPette™ model BP20*

Set the volumeter to 10  $\mu$ l. Aspirate a volume of liquid and measure it gravimetrically. If the corresponding volume is measured as 9.5  $\mu$ l, the error is 0.5  $\mu$ l. Increase the volumeter setting by 0.5  $\mu$ l to 10.5  $\mu$ l and repeat the measurement. If the second measurement is not accurate enough, adjust the volumeter up or down to take account of the remaining error.

When dispensing dense or viscous liquids, wait one or two seconds longer at the first stop before expelling the residual liquid.

## 6 - LABNET PIPETTE TIPS

**Labnet** tips are made from high performance polypropylene and their quality guarantees the precision and accuracy associated with the **BioPette™**.

Strict control is maintained throughout the manufacturing process to ensure the highest quality.

The accuracy and precision figures for the **BioPette™** are only guaranteed when **Labnet** tips are used. The use of inferior quality tips will seriously degrade the performance of the **BioPette™**.

Some **Labnet** tips are color coded and correspond to the color on the pushbutton.

### White tips 10

These tips are used for volumes between 0.1  $\mu$ l and 10  $\mu$ l. They are used with the BP2 and the BP10 models.

### Yellow tips 200

These tips are used for volumes between 2  $\mu$ l and 200  $\mu$ l. They are used with the BP20, BP100, and the BP200 models.

### Blue tips 1000

These tips are used for volumes between 100  $\mu$ l and 1000  $\mu$ l. They are used with the BP1000 model.

### White tips 5000

These tips are used for volumes between 1000  $\mu$ l and 5000  $\mu$ l. They are used with the BP5000 model.

### White tips 10000

These tips are used for volumes between 1000  $\mu$ l and 10000  $\mu$ l. They are used with the BP10000 model.

## 7 - RECOMMENDATIONS

The recommendations below will ensure maximum accuracy and precision from your **BioPette™**.

- Make sure to operate the **BioPette™** slowly and smoothly.
- The depth of immersion in the sample liquid should be the minimum necessary and should remain constant during aspiration.
- The **BioPette™** should be held in a vertical position.
- Change the tip when volume setting is changed or when a different liquid is to be aspirated.
- Change the tip if a droplet remains on the end of the tip from the previous pipetting operation.
- Each new tip should be pre-rinsed with the liquid to be pipetted.
- Liquid should never enter the **BioPette™** shaft. To prevent this:
  - Press and release the pushbutton slowly and smoothly
  - Never turn the pipette upside down
  - Never lay the pipette on its side when there is liquid in the tip.
- Never force the volumeter beyond its recommended limits.
- When pipetting liquids with temperatures different from the ambient temperature, it is recommended to pre-rinse the tip several times before use.

# BioPette™

- Do not pipette liquids with temperatures above 70°C.
- When pipetting acids or corrosive solutions which emit vapors, it is recommended to disassemble the shaft and to rinse the piston and seal with distilled water after finishing the pipetting operation.

## 8 - RECALIBRATION

The pipette is calibrated by gravimetric method, using distilled water, at the temperature  $20 \pm 1^\circ\text{C}$ , according to EN ISO 8655 standard.

If during pipette operation you find that the accuracy error (the difference between the real aspirated volume and the preset volume) exceeds the permissible value given in the table in section 1, the pipette recalibration procedure should be carried out.

Before starting the recalibration it is necessary to check whether the following requirements have been fulfilled during error determination:

- the ambient temperature, and the temperature of the pipette, tips and water was identical
- the density of the liquid used was close to that of distilled water
- a balance with appropriate sensitivity has been used

Volume checked [ $\mu\text{l}$ ]	Balance sensitivity [mg]
0.1 - 10	$\leq 0.001$
10 - 100	$\leq 0.01$
> 100	$\leq 0.1$

- mg/ $\mu\text{l}$  conversion factor has been taken into account
- the requirements given in sections 3 and 7 have been fulfilled

If the above conditions are satisfied and the accuracy error for selected volume given in section 1 exceeds the permissible value, the pipette recalibration procedure should be carried out.

**The recalibration can be performed within one full turn of the key to the right or to the left only.**

### Recalibration conditions:

- Ambient temperature and the temperature of the pipette, tips and liquid should be within the range  $20\text{-}25^\circ\text{C}$  and stabilized during weighing within  $\pm 0.5^\circ\text{C}$
- Measurements should be conducted using distilled water
- Balance sensitivity should be suitable for the volume to be controlled.

### Recalibration procedure:

- Set the dose volume depending on the pipette volume according to the following table:

Model	Range of the pipette volumes [ $\mu\text{l}$ ]	Preset volume [ $\mu\text{l}$ ]	Permissible volumes [ $\mu\text{l}$ ]	Volume change $\Delta V$ for full turn of the calibration key [ $\mu\text{l}$ ] (24 increments)
BP2	0.1 - 2	0.2	0.176 - 0.224	0.06
BP10	0.5 - 10	0.5	0.48 - 0.52	0.33
BP20	2 - 20	2	1.92 - 2.08	0.63
BP100	10 - 100	10	9.84 - 10.16	2.50
BP200	20 - 200	20	19.76 - 20.24	6.30
BP1000	100 - 1000	100	99.1 - 100.9	25.00
BP5000	1000 - 5000	1000	994 - 1006	125.00
BP10000	1000 - 10000	1000	975 - 1025	250.00

- Perform 5 aspirations, weigh each one and calculate the average value of the aspirations
- Calculate average aspirated volume in  $\mu\text{l}$  multiplying the average aspiration amount [mg] by the distilled water density coefficient [ $\mu\text{l}/\text{mg}$ ], which depends on temperature and pressure according to the following table:

Temperature [ $^\circ\text{C}$ ]	Pressure [kPa]		
	95	101.3	105
20	1.0028	1.0029	1.0029
21	1.0030	1.0031	1.0031
22	1.0032	1.0033	1.0033
23	1.0034	1.0035	1.0036
24	1.0037	1.0038	1.0038
25	1.0039	1.0040	1.0040

If the average aspirated volume exceeds the permissible value, the following should be done:



# BioPette™

- Remove the pipetting pushbutton, (Fig. 4A)

**Warning: The pipetting pushbutton consists of 2 parts: the knob (Fig. 1A2) and the pushbutton (Fig. 1A1). After removal of the pushbutton, both parts are separated.**

- Holding the volume setting knob to protect it against rotation, insert the calibration key into the cuts of the calibration screw, (Fig. 4B)
- Turn the key clockwise to reduce the aspirated volume, or counter-clockwise to increase the volume, (Fig. 4C). One full turn of the calibration key changes the pipette aspiration volume by the amount given in the table
- Take out the key and fix the pipetting pushbutton (Fig. 4D). The pipetting pushbutton should be fixed by placing the knob on the arbor first (Fig. 1A2) and then the pushbutton (Fig. 1A1).

Determine the average aspirated volume. The average volume should be within the permissible range given in the table. If the volume exceeds the values stated, the recalibration procedure should be repeated.

When pipetting liquids with physical properties considerably different from those of water, follow the rules given in section 5.

## 9 - TROUBLESHOOTING

If you notice an improper pipette operation identify the cause and eliminate the fault. To do this, follow the instruction in the sequence provided. Replacement of parts should be required only occasionally, and should not occur under normal pipette use.

### **Droplets of liquid remain in the pipette tip.**

- The tip is emptied too fast.  
**Decrease the speed of pressing the pipette pushbutton.**
- The tip wettability has increased due to extensive use.  
**Replace the tip with a new one.**

### **Droplets of air appear in the liquid aspirated into the tip.**

- The pipette tip immersion is too shallow.

### **Immerse the tip deeper according to the instructions.**

- The pipette tip is incorrectly pressed onto the pipette shaft.  
**Press the pipette firmly.**
- The tip is damaged or worn out due to extensive use.  
**Replace the tip with a new one.**

### **The pipette incorrectly aspirates the liquid or liquid drops out from the tip.**

- The pipette tip is incorrectly pressed onto the pipette shaft.  
**Press the pipette tip firmly.**
- The shaft nut is loose (Fig. 3F) in the models BP2-BP1000  
**Tighten the shaft nut.**
- The sealing surface of the shaft is cracked or scored.

**Remove the tip ejector. Unscrew the shaft nut, inspect the shaft and the piston assembly. Replace the damaged parts (see Section 12). When reassembling the pipette, the nut should be hand tightened.**

**In the models BP2, BP10 and BP20, the damage of the shaft may also cause a damage of the piston assembly. Replace the damaged parts (see Section 12).**

**When reassembling the pipette, the nut should be hand tightened.**

**To remove the tip ejector in models BP5000 and BP10000, remove the ejector pushbutton (Fig. 3N) and using a screwdriver unscrew the tip ejector by turning the screwdriver counter-clockwise.**

- Damage to the piston or seal due to prolonged use with the aggressive liquids.  
**Disassemble the pipette as described above. Replace the piston, seal and O-ring (see Section 12). Rinse the inside of the shaft in distilled water and dry. Lubricate the seal and O-ring with the lubricant, that has been included with each pipette.**  
**The replacement of the piston requires conducting of the calibration procedure.**

# BioPetite™

**Note: The parts of BP2 and BP10 pipette should be lubricated evently with a minimum amount of lubricant.**

- The pipette is reassembled improperly. **Disassemble the pipette and reassemble it, observing the proper sequence of steps (Fig. 3).**

- No lubricant on the sealing elements.

**Remove the tip ejector. Unscrew the shaft nut, remove the shaft, piston assembly, seal and O-ring. Rinse the removed parts in distilled water and dry thoroughly. Lightly lubricate the inside surfaces of the seal and the O-ring with the included lubricant. Reassemble the pipette in the reverse order.**

- Contamination of the inside of the pipette caused by extensive aspiration of chemically aggressive liquids or because liquid got inside the pipette.

**Remove the tip ejector. Unscrew the nut, remove the shaft, piston assembly, seal and O-ring. Rinse the removed parts with distilled water and dry thoroughly. Lightly lubricate the inside surfaces of the seal and the O-ring with the lubricant. Reassemble the pipette in the reverse order.**

**If you find an increase in the pipetting force, which could happen after repetitive autoclaving of the pipette:**

**Remove the tip ejector. Unscrew the shaft nut, and then remove the shaft, piston assembly, seal and O-ring. Rinse the removed parts in distilled water and dry. Lubricate the internal surfaces of the seal and O-ring with lubricant that has been included with each pipette. Reassemble the pipette in opposite order.**

**Note: All parts of the pipette can be autoclaved (see Section 10)**

**The shaft of the 5000 and 10000 models should be autoclaved without the filter.**

If the problem continues after carrying out the above steps, contact your **Labnet** representative.

Before returning the pipette, please ensure that the pipette is completely free of any chemical,

radioactive or microbiological contamination which could pose a threat during transport and repair. As far as it is possible, clean the pipette.

## 10 - CLEANING AND STERILIZATION

### Cleaning

External surfaces of the pipetting pushbutton, the ejector pushbutton, the handgrip, the shaft nut and the adjustment knob may be cleaned using a cloth dampened in isopropyl alcohol. The remaining parts removed from the pipette during pipette disassembly may be washed with distilled water or isopropyl alcohol.

### Sterilization:

The pipette can be sterilized in the autoclave at 121°C for 20 minutes. After sterilization, the pipette should be dried and cooled to room temperature.

### It is recommended:

- to sterilize the pipettes in an autoclave with an initial vacuum and drying cycle,
- prior to sterilization unscrew the shaft nut slightly in the BP2-BP1000 pipettes, and unscrew the shaft slightly in the BP5000 and BP10000. After autoclaving these parts should be screwed tight again.

The precision of the results should not alter if the pipetting process and autoclaving are carried out as described in this manual. Because a slight change in the accuracy of the dosage may occur, it is recommended to:

- check the calibration of the pipette after the initial first, third and fifth autoclaving cycles and then after every 10 autoclaving cycles.

# BioPette™

## 11 - PIPETTE KIT AND ACCESSORIES

### Pipette kit:

The pipettes are delivered in the kits including:

- Pipette
- Instruction manual
- Calibration key
- Ejector regulation spacers  
(for pipette models BP2 - BP1000)
- Ejector cap  
(for pipette models BP5000, BP10000)
- Identification labels
- Filters (for pipette models BP5000, BP10000)
- Lubricant

### Accessories

Cat. No.	Description
P4803-10	10 $\mu$ l tips, racked
P4803-200	200 $\mu$ l tips, racked
P4803-1000	1000 $\mu$ l tips, racked
P3998	5000 $\mu$ l tips, bulk pack
L943	10000 $\mu$ l tips, bulk pack
P3985	Carousel stand for 6 pipettes
P3989	Linear stand for 6 pipettes

## 12 - SPARE PARTS

The spare parts indicated in Fig. 3, 4 and 5:

**A: Pipetting pushbutton**

**A1: Pushbutton A2: Knob**

**B: Adjustment knob**

**C: Shaft**

**D: Ejector**

**F: Shaft nut**

**G: Piston assembly**

**H: Spacer**

**I: O-ring**

**J: Seal**

**K: Calibration key**

**L: Filter**

**M: Ejector cap**

**N: Ejector pushbutton**

can be ordered from a **Labnet** representative (type of the pipette and name of the part for this pipette should be specified).

**Warning: The replacement of the plunger requires conducting of calibration procedure according to section 8.**

Contact Labnet at 732-417-0700,  
fax:732-417-1750,  
email:labnet@labnetlink.com